

EMERSON

OFFLINE360



360

Packaging

product catalogue



Check out
all our products!

One of the largest producers of prints in Europe

Emerson combines almost 30-years of market experience, professionalism in its activity and innovative solutions for the Customers.

We have been present on the market since 1992. Thanks to our dynamic development, we are one of the largest European producers of specialized forms and printed matter such as scratch cards or classified documents.

We are continuously investing in modern technologies and multifunctional machinery. This is why we are constantly expanding the range of offered products and services.

The innovative solutions and the wide product portfolio are the attributes that significantly distinguish us on the market. We skillfully combine various printing, typesetting, and finishing techniques. We use non-standard formats and raw materials to meet the sophisticated expectations of our customers. We also provide co-packing, design, concept development, and many other operational solutions dedicated to business.

Briefly about us:

- ✓ 30 years on the market
- ✓ 100% Polish capital
- ✓ 200 employees
- ✓ annual turnover **PLN 162 million**

We process annually:

- ✓ 15 thousand tons of paper
- ✓ 100 million sheets of A4 labels
- ✓ 800 million sheets of A4 paper
- ✓ 300 million scratch cards

360



Certificates:

- ✓ ISO 9001:2015
- ✓ ISO 14001:2015
- ✓ ISO/IEC 27001:2017
- ✓ FSC certificate

FIRMA ROKU 2020



Office world



Sales support



Specialized prints

Table of Contents

Table of Contents

Warehousing

Storage space rental.....	06
PRO Warehousing.....	07
Logistics & E-commerce.....	07

Co-packaging & fulfillment

Co-packing: packing, finishing and goods distribution.....	10
Product and package labelling.....	10
Manual work.....	11
E-commerce handling - fulfillment.....	11
Packing using the FlowPack technique.....	12

Manufacturing of logistic and promotional materials

Manufacturing of product packaging.....	16
Dispatch, collective packaging.....	17
Die-cut packaging.....	17
Sendboxes.....	18
Poly mailer.....	18
Jiffy bags.....	19
SUMO jiffy bags.....	19
Safety envelopes.....	20
Doypacks.....	20
Stretch film.....	22
Zipper bags.....	22
Logistic printed matter.....	23
Promotional labels.....	23
E-commerce bags.....	24
E-commerce labels.....	24
Printed and unprinted address labels.....	25

Design and manufacturing of POS materials

Types of POS materials.....	29
Monolith stands.....	30
Modular stands.....	31
Counter displays.....	32
Displays.....	33
Chep.....	34
Wooden pallets.....	35
Cardboard pallets.....	35

Warehousing

360



Photo of Emerson Packaging warehousing facility located in Sosnowiec, Silesia, Poland.

Storage space rental

Every major manufacturer or on-line store requires a professional warehouse service. Some companies opt for the in-house service, some prefer the external service and others choose the hybrid service model. Each model has its own advantages and disadvantages, so you should carefully review your own needs and make the right choice.

Emerson Packaging offers consulting as well as short and long term warehousing services together with all related services

Our warehousing facilities are located in **Sosnowiec** and **Piotrków Trybunalski**, near the main exit routes leading to all directions in Europe. The location as well as our flexibility and fast pace of operations make us often involved in large projects. We are always happy to share our experience with our Customers.

Pallet holding position

There are **10 000** pallet holding positions at the disposal of our Customers. We strive to provide our Customers with comprehensive range of service to satisfy all their warehousing requirements. We are a reliable partner that will enable you to cut significantly the operating costs of your business.



PRO Warehousing

At our warehousing facility, there are products with different SKUs that need to be prepared for distribution. This is usually a manual process, because the range of goods and related operational services is so extensive that almost every project must be modelled from scratch.

We provide a professional and reliable approach to your every order. We have extensive experience in the distribution of various types of materials. We have already been trusted by many customers and companies representing very different industries.



Logistics, e-commerce

- **Handling of deliveries** – we will receive your goods, check them in terms of both quality and quantity.
- **Warehousing services** – we put at your disposal 5 000 m² of storage area.
- **Manufacturing of packaging** – we can produce for you a wide range of cardboard boxes, decorative packaging and envelopes.
- **Packing and shipping services** – your goods will be packed according to your instructions, and quality control will check the conformity of your order before dispatch.
- **Returns handling and record keeping.**

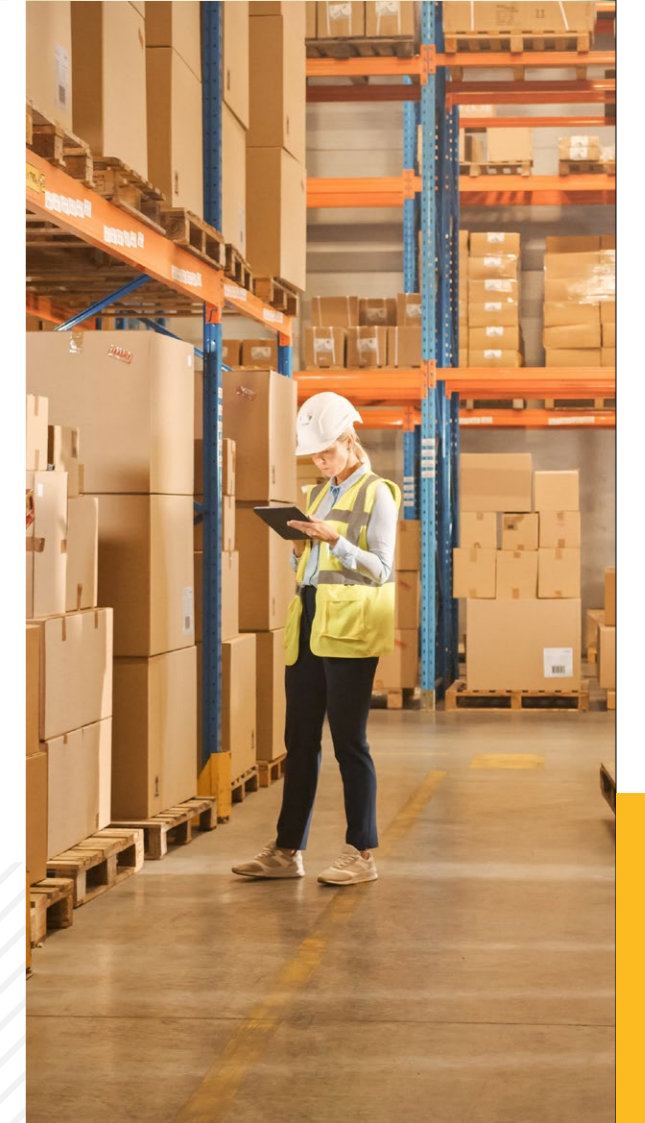

Co-packing & fulfillment

360



Co-packing: packing, finishing and goods distribution

These services include all necessary processes of enriching products with the indicated information, their specific packaging, the preparation for distribution, including the courier or freight distribution.

According to our definition, co-packing means the comprehensive handling of the logistics and manufacturing-service process that leads to the successful delivery of the right product to the final Customer in a timely fashion.



Manual work

The great majority of products available on the market at a certain manufacturing stage are handled manually. It is virtually impossible to automatize the entire process.

Therefore, we perform the following services to our customers on everyday basis:

- inserting services - into envelopes, boxes, foils, bags,
- gluing services - using hot and cold techniques, using an adhesive tape,
- picking - different components and using them to make one package,
- mixing of different products and packing them into the appropriate bulk or the promotional packaging,
- assembly of stands,
- placing goods on stands and displays,
- delivery of VAS (Value-Added Services),
- processing of e-commerce orders management, packaging and shipment.

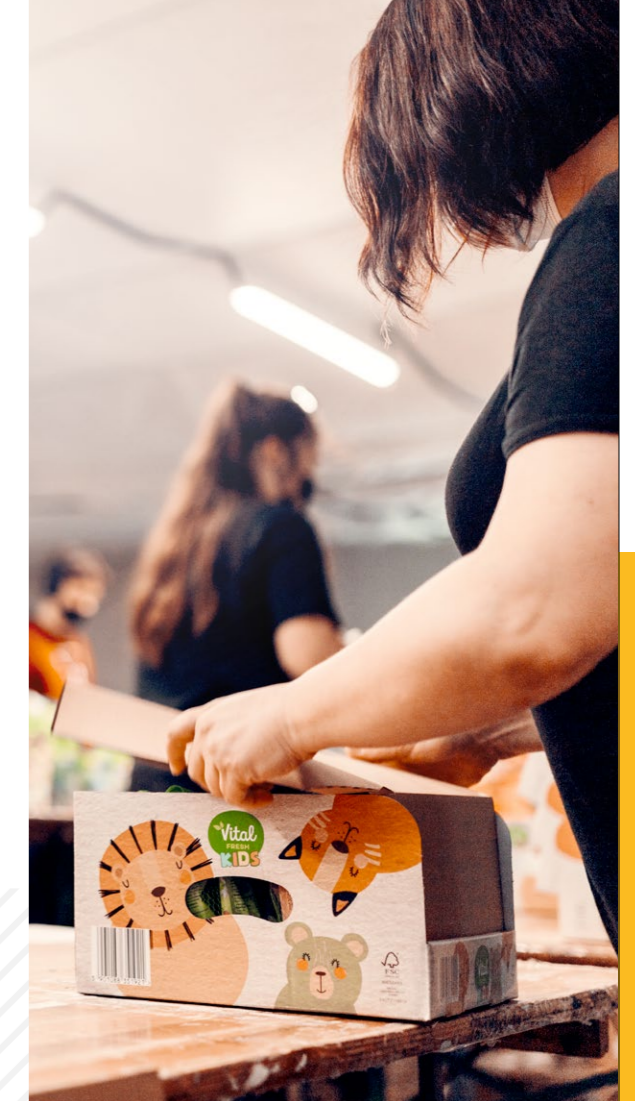

Product & packaging labelling

This is the most frequently performed service by us at the Packaging Department. Thanks to the fact that we are one of the largest manufacturers of specialized labels in Poland, we also receive many requests for additional service - sticking labels on the product. In response to the market needs, the labelling service was developed and has constantly been developing.

You can order from us:

- label design (including selection of raw materials and manufacturing process),
- label manufacturing,
- product labelling,
- putting into collective packaging,
- getting ready for distribution and distribution implementation.



E-commerce – fulfillment handling

Every on-line store requires the order processing. In simple terms, the process involves stocking goods, completion of orders, packing and shipping. In the initial phase of the store operations, we recommend self-service. However, as the time goes by, the orders are placed more and more frequently and reach the level of 300-500 plus packages per month, it is worthwhile to outsource this process to a third party company, such as ours, and focus on boosting sales.

We will handle the overall process, including handling returns and manufacturing all the items that have to be shipped - packaging, labels, parcel fillers, adhesive tape, courier services. Additionally, each customer will get sales support and ideas for effective marketing from us. To the shipments you can add other items such as leaflets, catalogues, gadgets, which will drive you into higher sales.





Packing using the FlowPack technique

Our offer includes film wrapping/packaging services on a horizontal FlowPack AHP-450-3S machine. It is used to pack/film wrapping of solid and regular items such as: masks, cutlery, sachets, toys, gadgets, collector cards, contest coupons, loose items placed on a tray or in a box, pens, writing pads etc.

We can use various heat-sealable, printed and transparent films and laminates for packaging. To stay in line with the latest trends on the packaging market, we also use biodegradable, compostable films made from the corn starch.

In addition to the packaging service, we can design the packaging for you and manufacture the film.

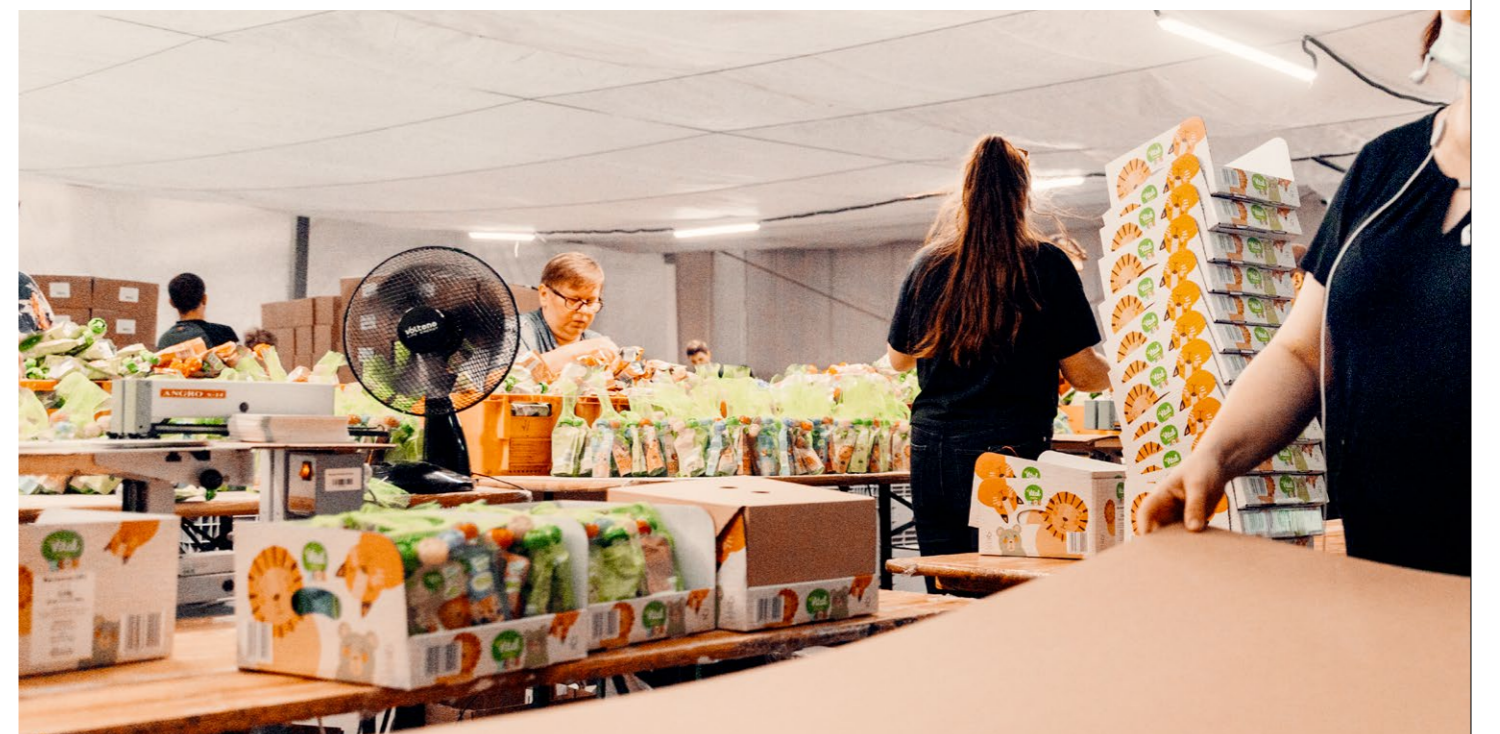

Illustrative process:

acceptance of goods, stocktaking, production of the unit packs, production of collective packs, packing into unit packs, packing into collective packs, palletizing, preparation for distribution to the sorting plants, then to the retail chain stores.



Manufacturing of logistic & promotional materials

360





Manufacturing of packaging

Not sure what packaging to choose for your product? Send your product to us or give us its parameters we will select raw materials and design the structure according to your instructions. Our graphic designers will also design graphics for your packaging.

The box appearance does matter

The product packaging can perform different functions depending on the type of articles we pack in it. Its main purpose is to protect goods from damage during the transport and storage. Therefore, the good product packaging should be robust and durable. But not only. It has to play a sales role, so it is necessary to take care of the right design - aesthetic, legible and eye-catching.

During the production of the cardboard packaging we follow the received guidelines. We always provide you with the professional advice. We will select the appropriate design, raw materials, printing technologies, finishing and deliver the final packaging on time.

Collective Packaging for Shipment

It is one of the simplest and most common packages, but without it it is often impossible to close the distribution process.

This type of packaging is used for transport and protection. It definitely makes the logistics easier. Depending on the weight and size of the contents, different types and weights of the used cardboard.

However, it is not enough to just apply this type of packaging to the given shipments. It is required to take care of the proper filling of the empty spaces. What is more, the packages need to be firmly sealed and labelled. We can also handle the whole process and advice within the Packaging service.



Die-cut Packaging

This type of packaging is often used to package products in e-commerce.

Cheap, aesthetic, easy for packaging. Thanks to its design, it has double walls when folded and is very robust. In this case care should be exercised as well to fill in the empty spaces in the packaging. We can apply overprint upon request (for orders 1000+ copies). For smaller volumes, we suggest using a pre-printed band. It is a cost-effective and eye-catching solution.

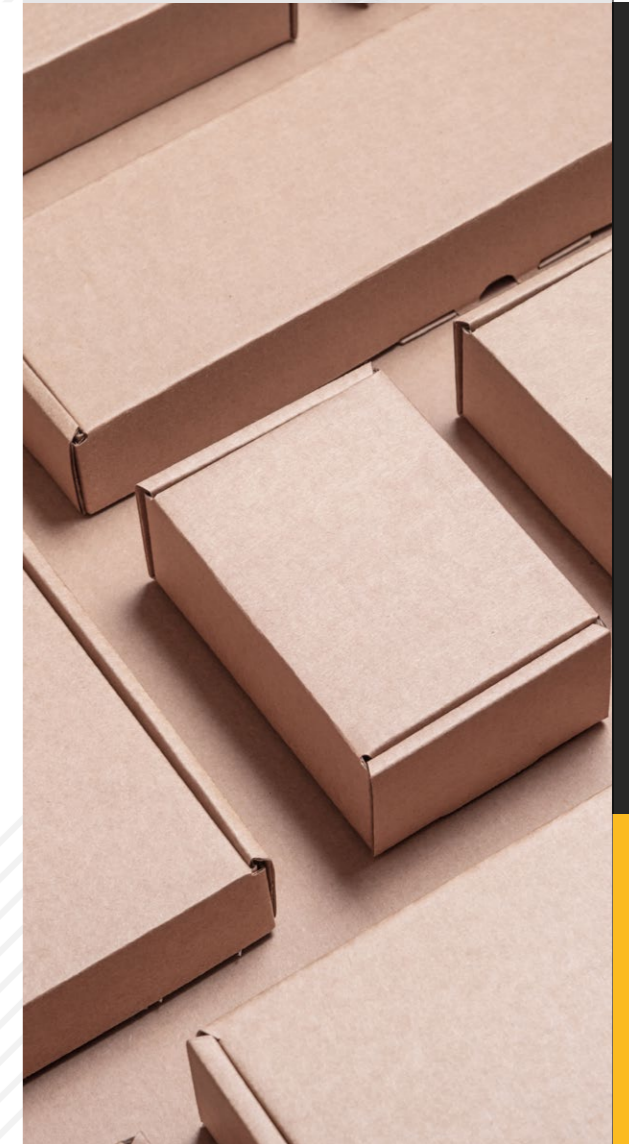

Sendboxes

It is one level higher than the standard die-cut packaging.

The design is very similar, but the flap - additionally armed with two adhesive tapes (one to close the package before shipping and the other to facilitate a return) and a tear-off - makes it easier to open the package without major damage, which is important for returns. Sendbox is a typical packaging used in e-commerce, which we can refine with a print or label band.



Jiffy Bags

Standard jiffy bags for everyday mailings. They are available in 11 formats, in white colour.

- Outer layer of white craft paper bleached without chlorine (ECF).
- Inner layer made of bubble wrap.
- Inner Triple Trifix closure (permanent closure, peel-off closure and punched under clip closure layer).
- Overprint made with water-based inks (Aquaprint).
- Trimmed corners of flap.

Additionally, jiffy bags up to the F/16 size can be overprinted, increasing the value of the shipment.

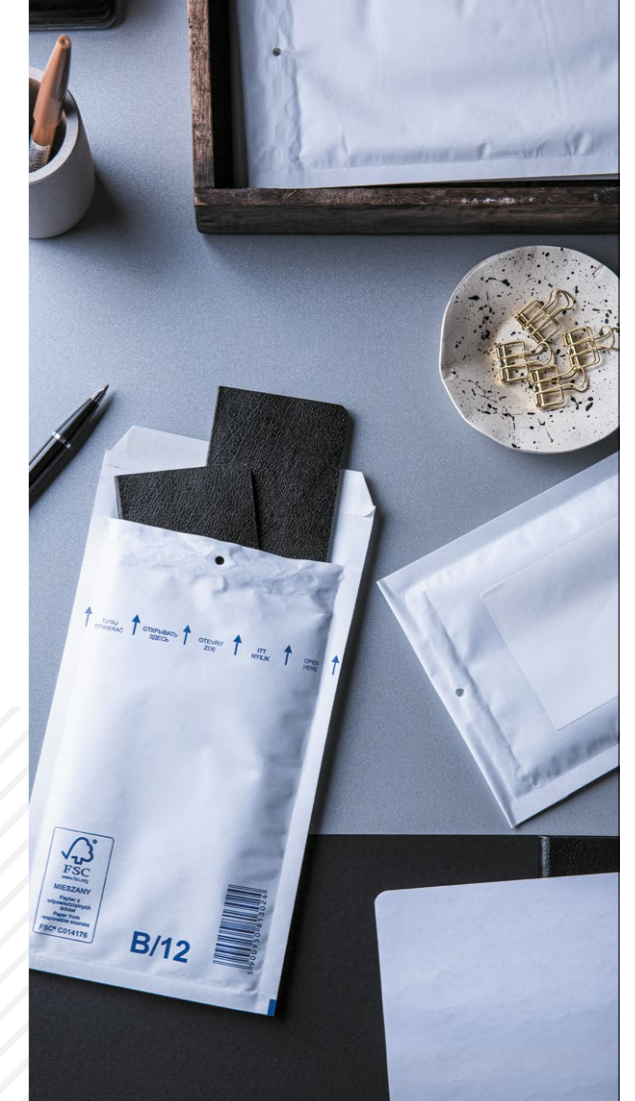

Poly Mailer

Thanks to eco trends, film packaging will slowly give way to more eco-friendly solutions, but it sometimes remains irreplaceable.

They are durable, moisture resistant and flexible. Therefore, they occupy a permanent position in our offer. Additionally, we can overprint them - MOQ 5000 pcs. The unprinted version MOQ - 1000 pcs.



SUMO Jiffy Bags

Nowadays it is no longer appropriate to use jiffy bags with films as the filling material. Therefore, an envelope has been created, with paper filler in between the layers.

We can print on both of its sides, as desired, without any restrictions. This gives it a backbone and motivating force, because the envelope, especially with its protective aspect, performs two functions. Firstly, it has to deliver the shipment in one piece to the addressee. Secondly, it has to make the addressee open the bag here and now, right after receiving it. Our bag performs undoubtedly the above two functions and it is additionally eco-friendly. Currently, it is hard to find bags with a more desirable set of features.





Safety Envelopes

They are used to transport and store particularly valuable shipments such as bank deposits, secret documents, keys etc.

The security system used in this envelope protects its contents from tampering by third parties. Any attempt to open it will leave visible traces of tampering. Any opening of the envelope is irreversible.

- Available colours: white, transparent.
- Available formats: B4, B5.
- 1000 pcs. per pack . (i.e. 5 packs with 200 pcs, including 4 small packs with 50 pcs).



Doypacks

A highly versatile packaging that is popular on numerous markets.

We offer craft doypacks with and without a window: from 250 ml to 3 l capacity. With and without overprint. You can also buy film doypacks with the labels used for branding purposes.



Stretch Film

Transparent and black stretch film for the optimal stabilization of courier and pallet shipments.

It combines durability, strength and flexibility. Indispensable at warehousing facilities, stores, wholesale warehouses and industry. The offer includes film for manual wrapping of goods on pallets and machine film - available upon request.

We offer the tailor-made film matching the individual customer's needs - including the parameters such as width, length, colour, intended use.

We also offer a mini-rap device designed for e.g. warehouses, offices, mail order.



Logistic Printed Matter

We offer logistic and courier printouts in the form of simple labels for thermal or thermal transfer printing or self-adhesive sets. These sets may consist of several pages of a form provided with an individual barcode.

We develop courier and forwarding labels from scratch, guaranteeing both the choice of raw material for the face and liner, as well as the choice of adhesive depending on the type of surface on which the labels will be applied. Under customized orders of the customers, we can also personalize the labels and perform die-cutting on both sides.



Zipper Bags

Used to store small items.

They are ideal for transporting small parts in bulk, which eliminates the risk of losing the contents. They are suitable for the storage of: herbs, spices or dried fruit, jewellery, semi-finished products, gaskets, rubber bands, screws, etc.

Transparency of the zipper bags makes it easier to identify and locate items.

The advantages of our zipper bags are as follows:

- high quality zipper closure,
- wide range of sizes,
- food grade packaging.

Zipper bags are offer in standard and premium versions.



Promotional Labels

Any shape, size and colour guarantee customization of the price list to the individual customer's needs.

These labels can be printed with an individual logo or dedicated graphics. The type of core, the used raw material, and the length of the beam are fully customizable. As one of the few providers, we offer printing with a special fluorescent paint. Such a label certainly cannot go unnoticed.

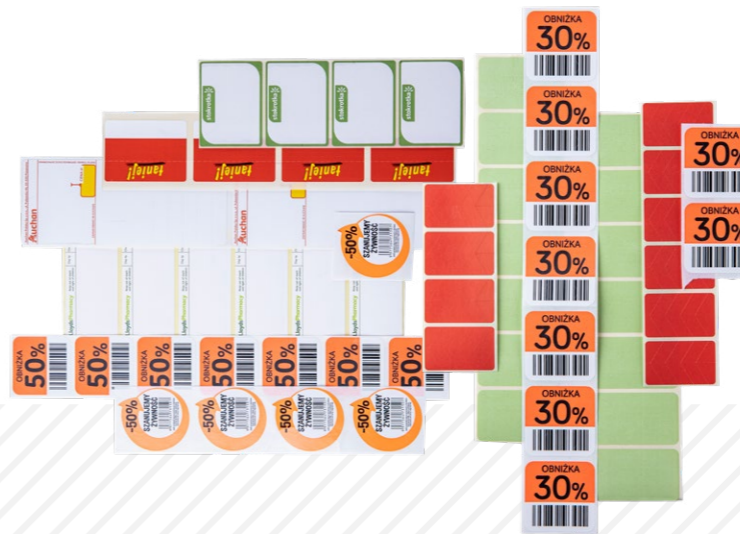

E-commerce Bags

Highly durable, roomy, eco-friendly, and armed with e-commerce tools - double closing straps plus a tear-off strap.

Available in both unprinted and printed versions.



E-commerce Labels

A convenient solution for e-commerce, fully laser printable, with perforations for tearing off individual parts of the print.

Upon Customer's request, we can place a unique bar code on the form. From now on, there is no need to include an order form, return instructions, and address label with your shipment. Our solution combines the functionality of all these elements. This is why it has also gained wide recognition among consumers.



Printed and unprinted address labels

We also offer everything else that you need to close the logistics or sales process. We manufacture labels for all industries. From the simplest blank labels to the specialized and registered labels - with the personalization and strictly pre-numbered. We can supply the labels themselves or labels with an application on the product.



Design & manufacturing of POS materials

Your product deserves to be displayed effectively!
The investment in displays pays off.



What characteristics does an effective display have according to our definition?

- ✔ The display has to be eye-catching.
- ✔ The display should allow the product to be easily „dispensed” to the Customer.
- ✔ The design and dimensions must comply with the specifications of the point or display venue.
- ✔ The cost of production has to be attractive enough to justify the use of display in the sales process.
- ✔ Its distribution should be trouble-free.

We can handle the overall process, including lining up your products on the display.

We treat each order individually and will be happy to create a stand that fits your needs! Each product offered by us can be made in an eco variant.





Printed and unprinted stands, monolith and modular

We are a renowned and experienced manufacturer of advertising stands. The quality of our services is proven by a wide range of satisfied partners and an impressive number of inventive implementation projects.

Manufacturing of craft counter displays is our specialty. We know perfectly that displays and stands are a great way to obtain attractive exhibition, which influences sales effectiveness. It is crucial to adapt POS materials to the nature of the offer, type of product and sales context. We know how to do it, because we have been helping our Customers from many industries in running their business for years. We do not only design and manufacture POS materials, but we also take care of their merchandising.

We know how hard it is to create a product, but we also know how hard it is to sell it.

In the online channel global digital campaigns are used for this, whereas in the offline channel - our counter displays. Show us what you want to display and we will give you the optimal tools to do so.

We efficiently and accurately select structures and raw materials for both light and very heavy, bulky and delicate, budget and valuable products.

Each of your products deserves good exhibition

Types of POS materials



01

Monolith Stands

They are used for heavier products because their solid design makes them stable and robust.



02

Modular Stands

These are stands that consist of multiple components. The shops prefer this type of solution because it can be managed freely in the store space. The modules sold out of the goods are pulled down to provide the customers with easier access to the products.



03

Counter displays

They are characterized by a simple design, small size, and thus low price. Thanks to the topper, usually available in the set, it is well visible.



04

Displays

Bulk packaging that is used for heavier or bulky products. They facilitate logistics and lining the shelves in stores. They have various sizes - adapted to products. Usually the set comprises a cover.

How cardboard stands and displays are manufactured?

We have been manufacturing cardboard stands and displays for years. We provide full and professional service of the overall manufacturing process. We develop manufacturing nets, mock-ups, printing, packaging and customizing as well as distribution. Places emphasized by the stands and cardboard displays naturally attract the attention of potential customers. Visually attractive presentation is essential. Not without significance is the stability of the structure itself, its functionality, practicality and accessibility. Stands and displays allow to present in an attractive manner various types of products or advertising materials at trade fairs, exhibitions and points of sale. The appearance of the stand should encourage people to become acquainted with the materials presented on it.



01 Monolith Stands

There are some examples of monolith stand models that are most often used during in/out campaigns in the chain stores.

Looking for fancy forms or non-standard finishing unfortunately does not translate into profitability of the campaign, because it involves high costs that will not pay back. A fancy stand will sell as much as a standard one. The presented designs are good enough to sell effectively - provided that they stand at a visible place in the store. But certainly, if it is our Customer's wish, we can and like to design very complicated and expanded stands.



02 Modular Stands

This group refers to the most popular displays on the market.

We perfectly understand why, even though they are not among the cheapest. It is just because the chain stores like them a lot and prefer them in negotiations. The reason? Because the modules can be placed throughout the store, speeding up the sales process, and the sold out modules are disposed, freeing up space in the store. It is unlike in the case of monolith stands, where you have to wait until the last product has been sold out from the stand, before you can dispose of it, thus freeing up space.



04

Displays

An example of collective packaging with a display function.

It should be born in mind while designing a price list, because without them it is usually impossible to enter any store shelf, and they represent the real cost. We will design a display optimally suited to your product.



03

Counter Displays

There is no better place to display the products at a store than on the counter at the checkout.

Everyone wants to get there, and many do, but because of this we always have very little space for displays. We design our displays to take maximum advantage of the opportunity - as many products as possible in a small space and at a low cost.





Wooden Pallets

We also trade in wooden pallets.

We can supply any quantity of wooden pallets, of any quality (Grade 1, Grade 2, Euro and industrial pallets) and any size.

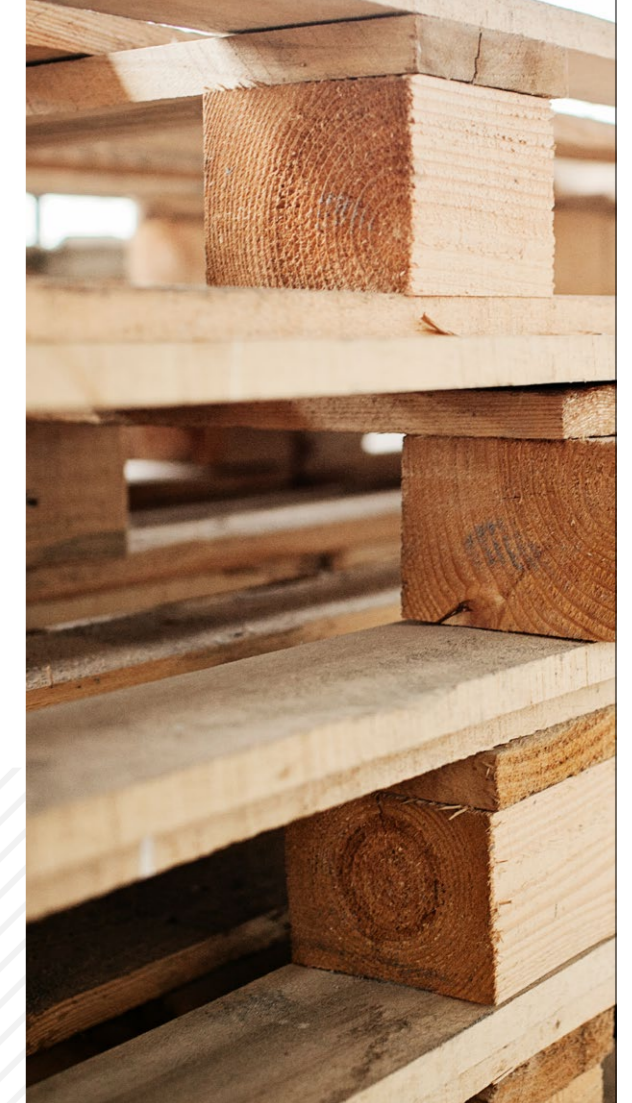

Add-on Services

Chep

All our designs can be enhanced with the special Chep pallet clips.

WE DO NOT TRADE IN CHEP pallets, but our stands are certainly designed to be mounted on them.

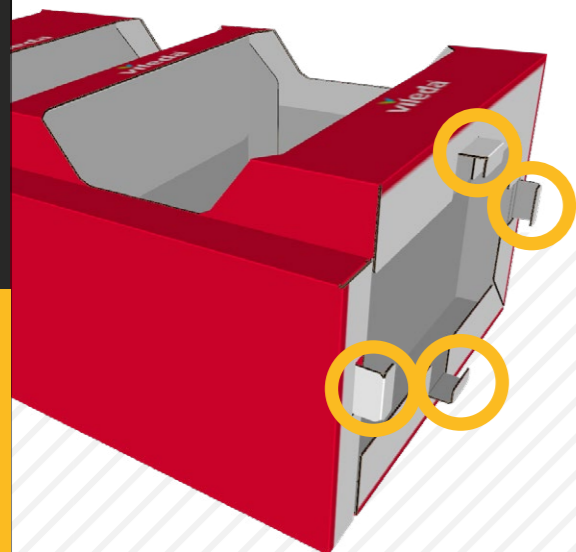

Cardboard Pallets

Eco-trends are also noticeable in the pallet market, therefore pallets made of recycled cardboard are also a must in our offer.

To this extent we can also develop a custom product, adjusting not only the format but also the pallet strength.

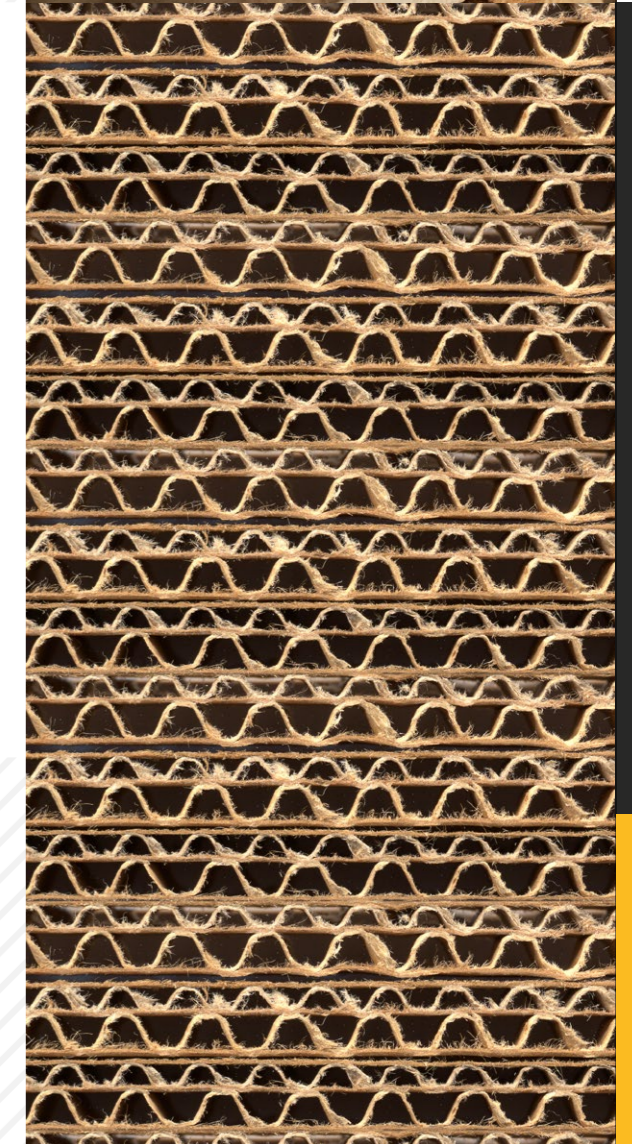



Packaging

The department that handles extensive co-packing services for companies from **retail and e-commerce** market, is located in Sosnowiec (Silesian voivodship). Over 20 years of experience of hand-made work, including fulfillment, lets us deliver almost every order related to co-packing and customization of (pre-packed) food and non-food products.

03